

Haier

Heat pump Water Heater Operation and Installation Manual



Model

HP150M5



English

Please read this manual carefully prior to your use of this water heater.

The appearance of the water heater given in this manual is for reference only.

Contents

1. Safety instructions	3
2. Instructions on transportation and storage.....	6
3. Functionings & principles	6
4. Technical parameters	7
5. Description of parts and components	8
6. Installation introduction	11
7. Operation and functions	24
8. Checking and maintenance.....	27
9. Faults and protection	28
10. Product Fiche	29

Dear users of Haier,

Thank you for choosing Haier products.

Please read this manual carefully and follow the operation and safety instruction to ensure best installation and utilization of the product.





Product safety statement:

- 1. This appliance can be used by persons with reduced physical, sensory or mental capabilities or lack of experience and knowledge if they have been given supervision or instruction concerning use of the appliance in a safe way and understand the hazards involved.**
2. Children shall be closely supervised to make sure they stay away from this product.
3. The method of installing safety valve please refer to Page 16.
4. The water may drip from the discharge pipe of the pressure relief device and this pipe must be left open to the atmosphere.
5. The water heater is to be drained according to the instructions specified on page 27.







Safety instructions (to be followed at any time)

Interpretation of marks and symbols









Failure to respect these instructions may lead to serious malfunctions of the device and to risks for the user

	<p>Instructions with this warning mark shall be strictly followed during operation. They relate to product and body safety of users.</p>
	<p>Information provided with this banning mark relates to activities that are definitely forbidden. Otherwise the machine may be damaged or users may risk personal danger.</p>







English

  <p>The water heater shall be installed in strict accordance with local wiring regulations, and equipped with power supply with a ground line. Please ensure an effective ground connection.</p>	 <p>Ground line and zero line of the power supply shall not be connected together. The ground line shall not be connected to pipeline conveying gas or water, lightning arresters or telephone lines.</p>
 <p>The water heater shall not be installed at places where water drainage is unavailable or impossible.</p>	 <p>It is recommended that the water heater shall be installed inside.</p>
 <p>This water storage tank must be equipped with a safety valve. Its installation position shall not be changed. To guarantee safe operation, it shall not be blocked at any time.</p>	 <p>While bathing, children must be under guidance of an adult person.</p>

Safety instructions (to be followed at any time)

 <p>The outlet water temperature of a water heater is typically higher than the temperature indicated on the display. Hot water shall not be pointed at the human body immediately after opening the hot water valve to avoid injury caused by hot water.</p>	 <p>Means for disconnection from the main supply having a contact separation in all poles that provide full disconnection under overvoltage category III conditions must be incorporated in the fixed wiring in accordance with the wiring rules.</p>
 <p>Install the water heater in strict accordance with the installation instruction specified on page 11-23.</p>	 <p>If the power cord is damaged, it shall be replaced by qualified professionals to avoid hazards.</p>
 <p>Hands or other items shall not be put into the air grille to avoid injury or damage to the water heater.</p>	 <p>Maintenance shall be carried out according to the instructions specified on page 27.</p>
 <p>The water heater is intended to be permanently connected to the water mains and not connected by a hose-set.</p>	
 <p>Do not install the water heater in the position where exposed to gas, vapours or dust.</p>	
 <p>The inlet water pressure is between 0.1-0.5MPa. The inlet water temperature is suggested between 10-30°C.</p>	

Safety instructions (to be followed at any time)

<p> Rotate the safety valve handle once a month. The valve works well if there is water flowing out, otherwise check for blocking and replace the safety valve if necessary.</p>	<p> Water heaters shall be equipped with a dedicated power line and residual current circuit breakers. The action current shall not exceed 30 mA;</p>
<p> The water drain pipe shall be in connection with the atmosphere, it shall not be blocked; the water drain pipe connected to a safety valve shall be installed in a frostless environment with an continuous downwards inclination.</p>	
<p> The appliance contains fluorinated greenhouse gases. Chemical name of the gas: R134a/ 0,45Kg Fluorinated greenhouse gases are contained in hermetically sealed equipment. Global Warming Potential(GWP) : 1430</p>	
<p> If needed, please refer to the wiring diagram on page 23.</p>	
<p> The method of connection about the appliance to the electrical supply refer to page 21.</p>	
<p> In accordance with safety rules, a safety valve(8bar,G1/2F) must be installed on the tank. For France, we recommend hydraulic safety units fitted with a membrane with the NF marking. The rated pressure of the safety valve shall not exceed 0.8MPa.</p>	

Instructions on transportation and storage

1. During transportation or storage, the heat pump water heater shall be packed in the undamaged package to avoid damage to appearance and performance of the product;
2. During transportation or storage, the heat pump water heater shall be in the upright position;
3. Under special conditions, this product may be laid down for a short time/distance as per indication on the side of the package case. The heat pump water heater, after being laid down for a certain time, shall be kept at upright position for more than 4 hours before starting up.



The machine shall be kept in the upright position at any time for the best performance !

Functionings & principles

A low-pressure liquid refrigerant is vaporized in the heat pump's evaporator and passed into the compressor. As the pressure of the refrigerant increases, so does its temperature. The heated refrigerant runs through a condenser coil within the storage tank, transferring heat to the water stored there. As the refrigerant delivers its heat to the water, it cools and condenses, and then passes through an expansion valve where the pressure is reduced and the cycle starts over.

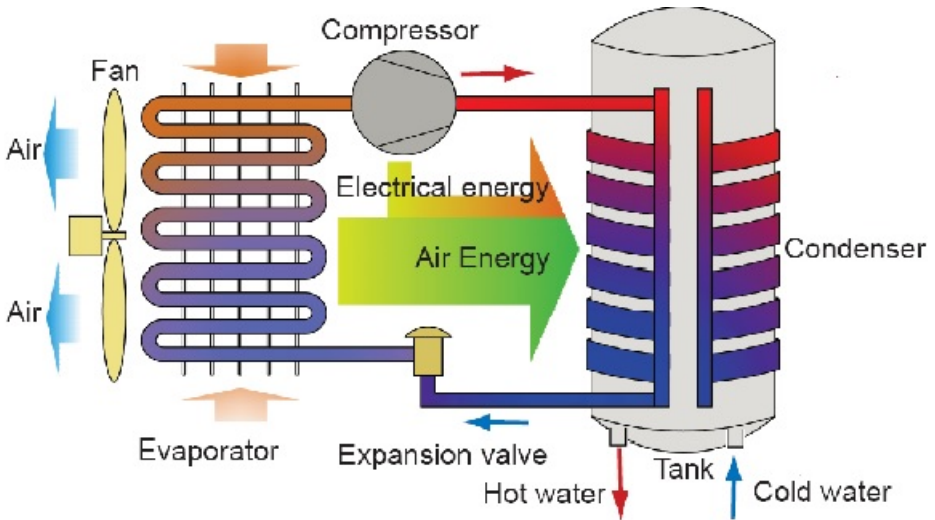

Technical parameters

Model	HP150M5
Tank	
Tank volume	150L
Rated voltage/ frequency	220V~240V/50Hz
Tank rated pressure	0.8MPa
Corrosion protection	Magnesium rod
Water proof grade	IPX4
Performances	
Type of extraction	Ambient / Exterior
COP@7 °C / EN16147	2.99
COP@14 °C / EN16147	3.58
Tapping cycle	L
Power input by electric backup	1200W
Rated power input by heat pump	240 W
Maximum power input by heat pump	350W
Maximum power input	1550W
Standby power input/ Pes	20W
Max volume of usable hot water at 40°C setting at 55°C	195.9L
Heating up time (7°C)	10h29
Heating up time (14°C)	8h28
Default temperature setting	55°C
Temperature setting range- with heater	35°C-75°C
Maximum length of air duct	5m
Diameter of air duct connection	160mm
Max working pressure of refrigerant	0.8/2.8MPa
Refrigerant type / weight	R134a/0.46kg
Sound power level	50dB
Ambient temperature for use of product	-7-45°C
Operating temperature of heat pump	-7-45°C
Dimension and connections	
Water inlet and outlet connection	G1/2" M
Safety valve connection	G1/2" M
Drain & Water inlet connection	G1/2" M
Product Dimensions	492*537*1680mm
Packing dimension without pallet	587*587*1764mm
Packing dimension without pallet	587*587*1894mm
Net/Gross weight	67/89kg
<p>* The COP and noise level data was tested in Haier lab. The COP values obtained with external air temperature of 7°C and 14°C, inlet water temperature of 10°C and set temperature of 54°C (according to EN 16147).</p>	

Description of parts and components

Heat pump structure

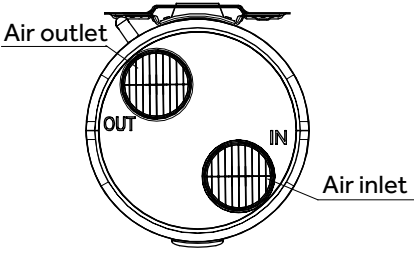
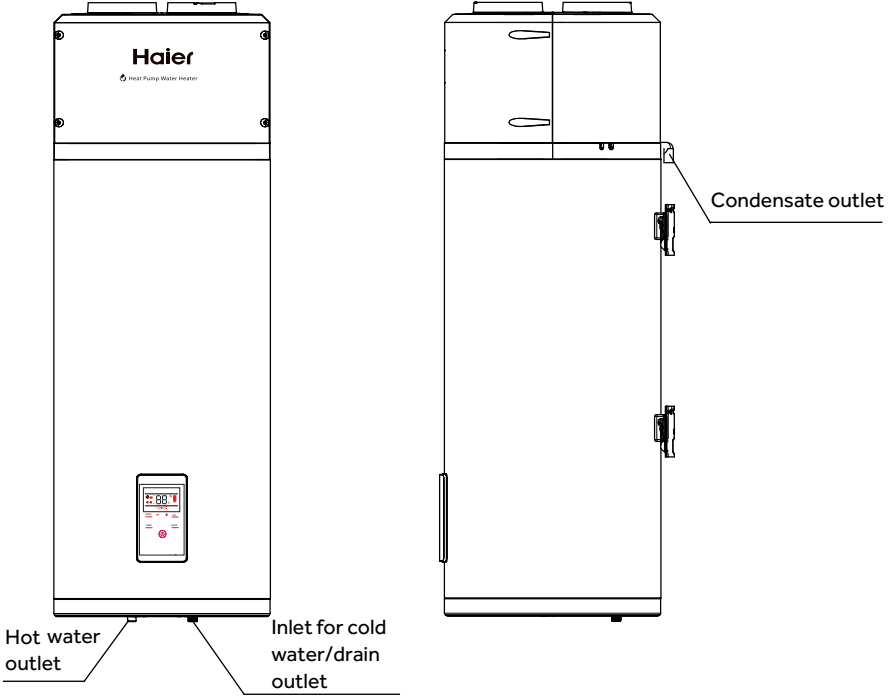

Accessories

Part name	Heat pump water heater	Safety valve	Drainage pipe for condensate water	Support plate	Instruction manual
Quantity	1	1	1	1	1

Description of parts and components

Exploded view

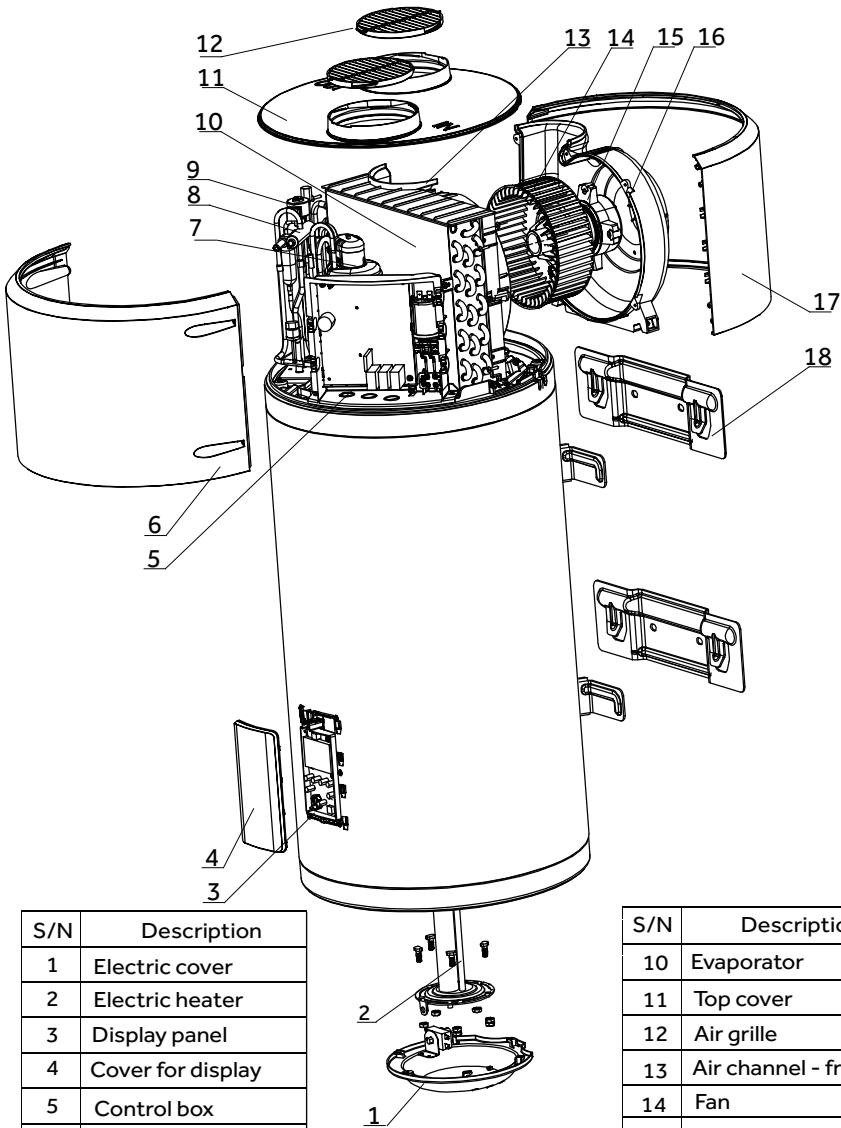

S/N	Description
1	Electric cover
2	Electric heater
3	Display panel
4	Cover for display
5	Control box
6	Front cover
7	Compressor
8	Four-way valve
9	Electronic expansion valve

S/N	Description
10	Evaporator
11	Top cover
12	Air grille
13	Air channel - front
14	Fan
15	Motor
16	Air channel - back
17	Back cover
18	Support plate

Installation introduction

Installation precaution

- Do not install the water heater in the position where exposed to gas, vapours or dust.
- Install the appliance on a flat, solid surface. The surface can support the machine weight and the condensate water can be drained freely.
- Noise due to operating and air flow do not bother neighbors.
- Make sure there is sufficient space left for installation and maintenance.
- There is no strong electromagnetic interference around that may affect control functions.
- There is no sulfur gas or mineral oil existing at the installation place, which may cause corrosion of the machine and the fittings.
- The water pipe for the water heater used at temperatures below 0°C shall not freeze.
- It shall not be set in rooms where a heating system is used so that heating supply to the room will not be affected.
- It shall not be set inside a totally-enclosed space.
- The air taken in must in no event be dusty.
- Install the appliance in a dry, frost-free room.
- Temperature of the ambient air or of the air taken in by the heat pump for optimum running: from 2 to 35°C.

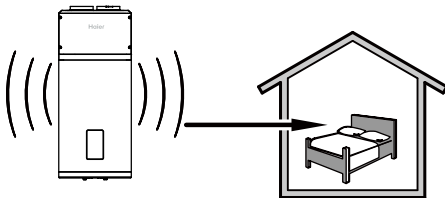

 Keep an adequate distance between the working heat pump and the resting room.

Installation introduction

Installation dimensions

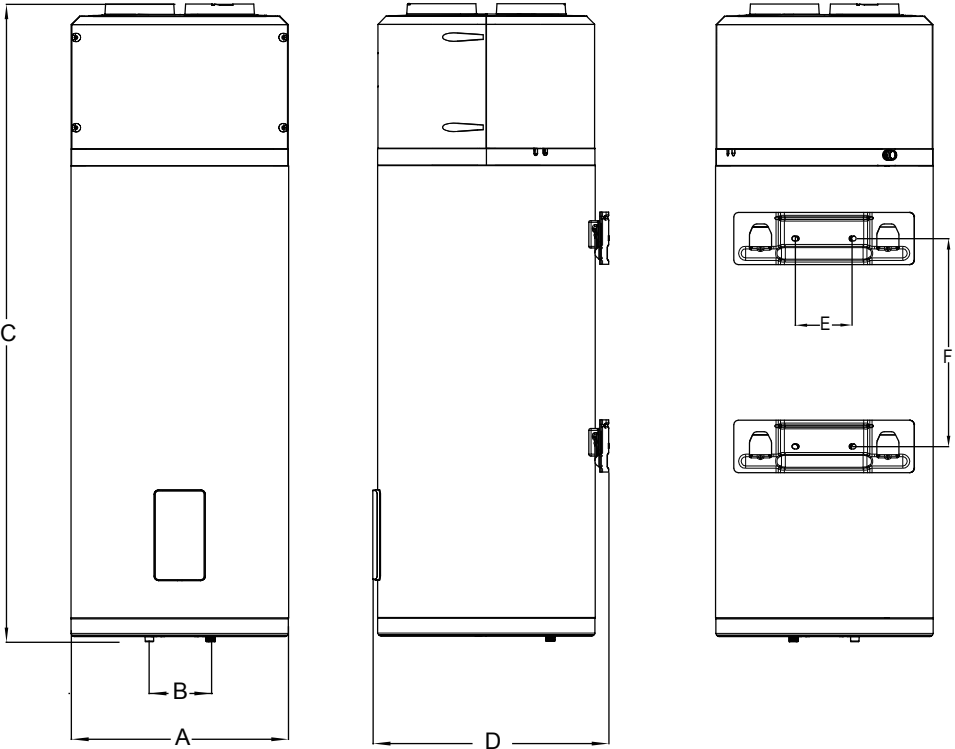

English

Unit:mm

Model	A	B	C	D	E	F
HP150M5	492	140	1680	534	159	470

Installation introduction

Installation dimensions

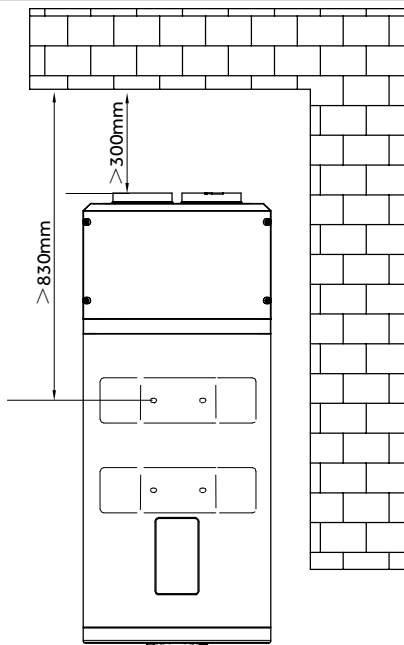

Note: These two expansion bolts can support 250kg weight at least. Please use the expansion bolts adapted to your wall material.

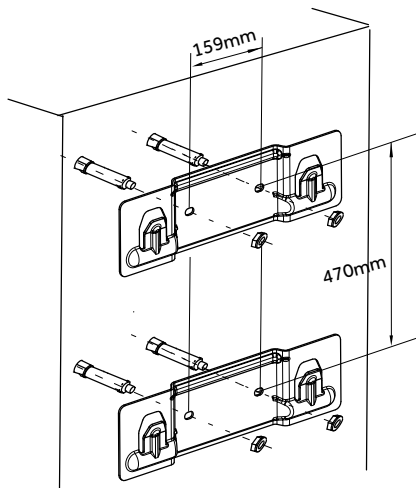

Installation angle refer to the following diagrams :

After the installation is completed, it is necessary to use a level ruler to check whether the support is maintained in a horizontal state.

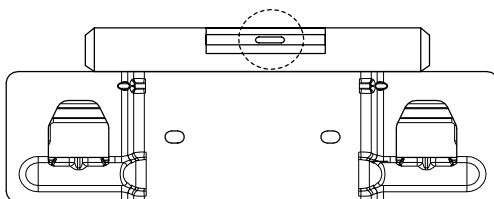
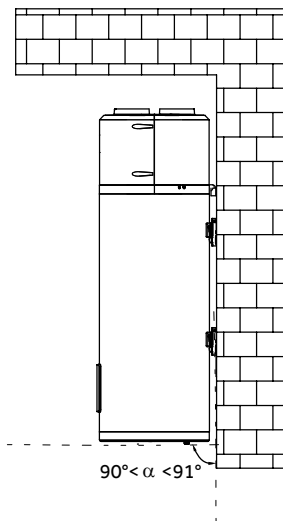

Installation introduction

Air connection

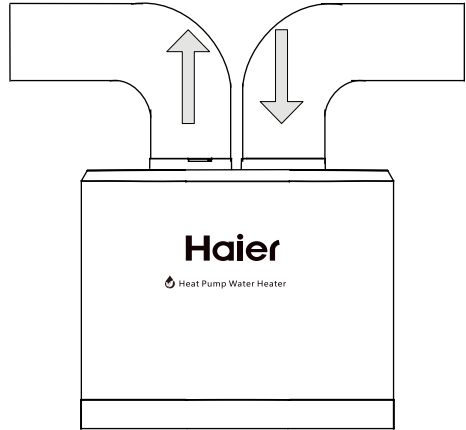
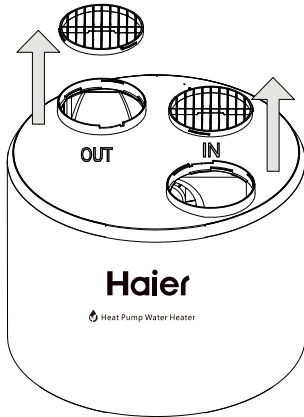

- Remove air grille first.

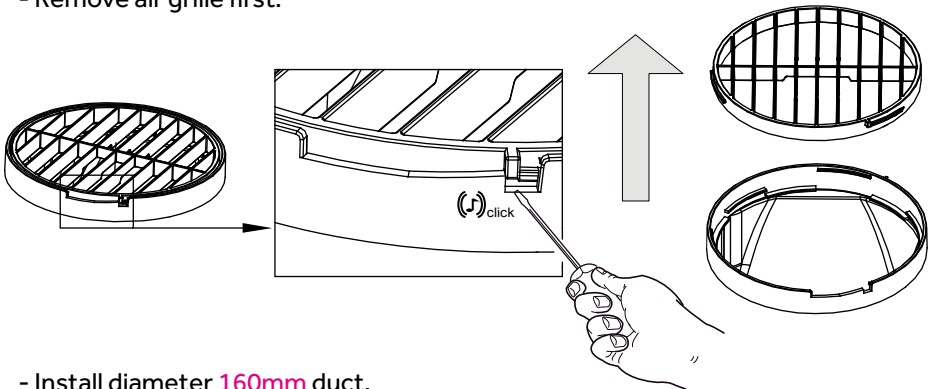

- Install diameter **160mm** duct.

- Pressure drops from duct must be lower than or equal to the static pressure of the fan.

- If the pressure drops out of range, the performance of the appliance will be impaired.

The sum of the maximum length of the air duct is 5m.

Installation introduction

Advised positions

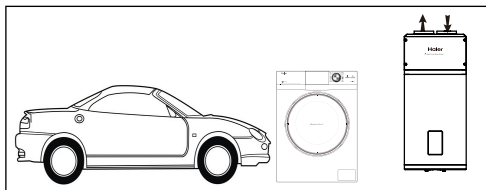

Garage or laundry room (without ducts):

- Unheated room.
- Enables recovery of the free energy released by your vehicle's engine when switched off after use or by household appliances in operation.

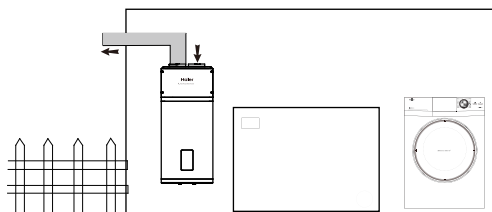

Laundry room (with one duct):

- Unheated room.
- Enables recovery of the free energy released by your vehicle's engine when switched off after use or by household appliances in operation.
- Referring installer menu (P26), adjust the fan speed.

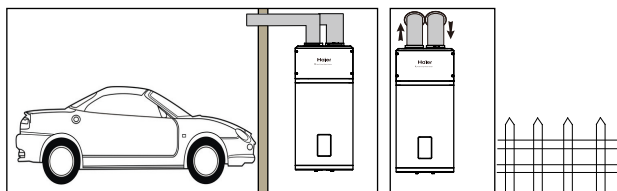

Habitable room or outside air (with two ducts):

- Can obtain free heat from the garage.
- If the outside air temperature is **too** low, connection to the outside air may lead to overconsumption of electricity.
- Referring installer menu (P26), adjust the fan speed.
- Avoid refreshing heated room.

Installation introduction

Installation caution



When making the connections, you should respect the standards and local directives.

- Before making the connection, rinse the water inlet pipes, in order not to introduce metal or other particles into the tank.
- Select copper pipes for pipeline connection.
- The inlet water pressure is between 0.1~0.5MPa. If lower than 0.1 MPa, a booster pump shall be added at the water inlet; if higher than 0.5 MPa, a pressure relief valve shall be added at the water inlet.
- The inlet water temperature is suggested between 10-30°C.
- Outdoor water pipeline and valves should be proper insulated.
- In accordance with safety rules, a safety valve(8bar,G1/2F) must be installed on the tank.For France, we recommend hydraulic safety units fitted with a membrane with the NF marking.
Integrate the safety valve in the cold water circuit.Install the safety valve close to the tank in a place which is easy to access.
No isolating devices should be located between the safety valve or unit and the tank.
The rated pressure of the safety valve shall not exceed 0.8MPa.
- Never block the outlet of the safety valve or its drain line for any reason.
- The diameter of the safety unit and its connection must be atleast equal to the diameter of the domestic cold water inlet.
- If the mains pressure exceeds 80% of safety valve, a pressure reducer must be installed upstream of the appliance.
- NOTE: Don't install and use the product outdoors.



If the air inlet and outlet of the product are not installed with air ducts, the air inlet and outlet of the product shall be protected to prevent water inflow, and the waterproof measures shall reach IPX4 level.

Installation introduction

Pipeline installation diagram

Installation A

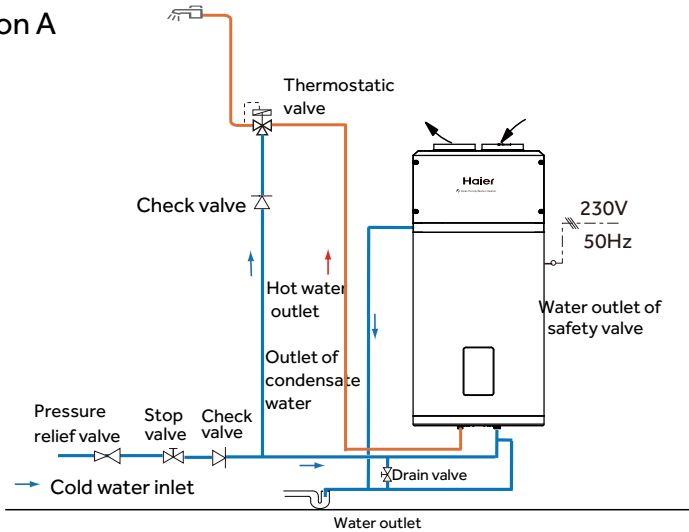

Installation B (for France only)

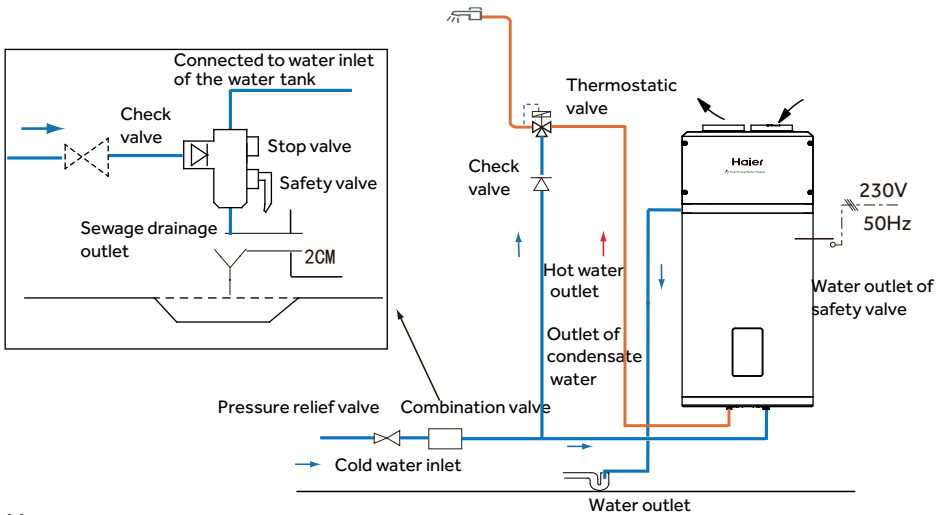

Note:

- Pressure relief valve, thermostatic valve, stop valve, check valve, T&P valve and French combination valve are not included in the accessories, please select proper fittings in local market;
- Valves with NF/CE certification are recommended ;

Installation introduction

Electrical connections precautions



WARNING

- Only qualified professionals may carry out electrical connections, always with the power off.
- The earthing shall comply with local standards.

- Water heaters shall be equipped with a dedicated power line and residual current circuit breakers. The action current shall not exceed 30 mA;
- The ground line and the null line of the power supply shall be separated entirely. Connecting the null line to the ground line is not allowed.
- Parameter of the power line: $3 \times 1.5 \text{ mm}^2$ or more.
- If a power cable is damaged, it shall be replaced by qualified professionals to avoid risks.
- In the case of places and walls where water may be splashed to, installation height of a power socket shall not be less than 1.8 m, and it shall be ensured that water would not be splashed on these places. The socket shall be installed out of children's reach.
- The phase line, zero line and ground line inside a power socket used in your home shall be wired correctly without any wrong positioning or false connection, and internal short circuit shall be avoided. Wrong wiring may cause fire accidents.

Connection to a PV system

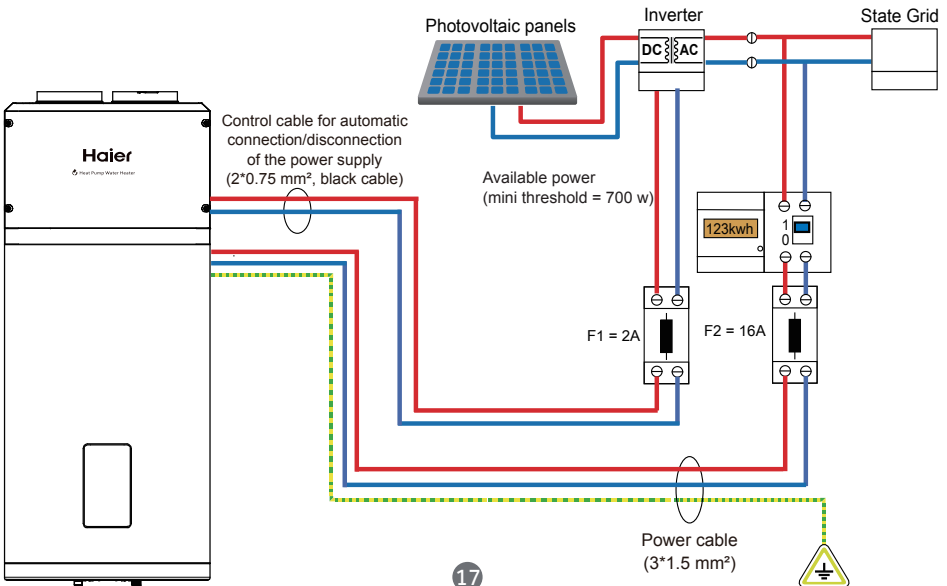

Installation introduction

Off-peak power signal wire connection

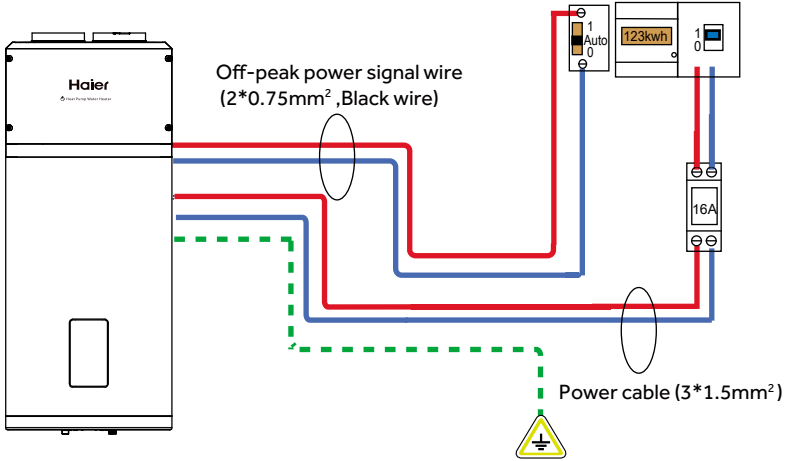

Installation introduction

Wiring diagram

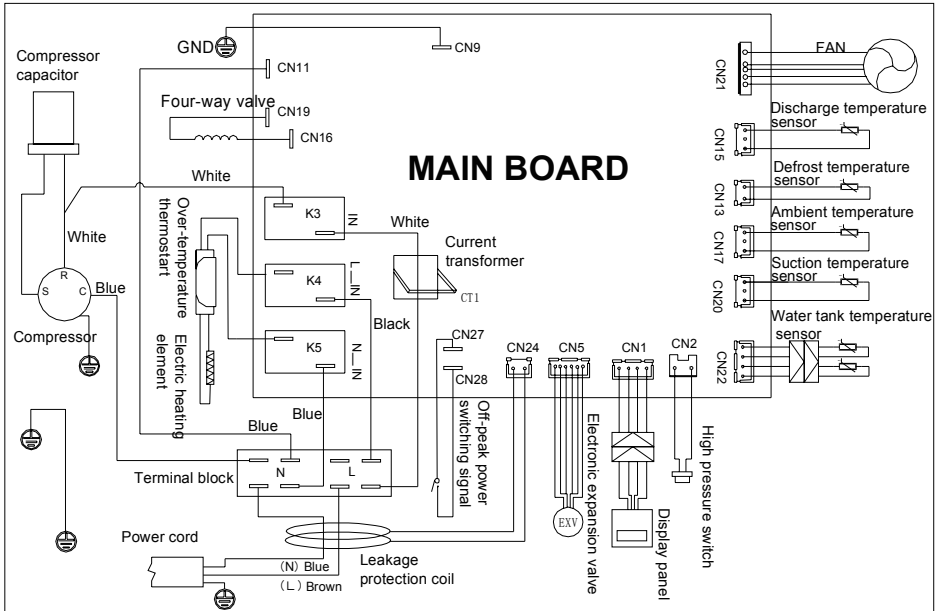

English

Commissioning

Installers shall use checking list for trial operation of water heaters as per the user manual and make ✓ in □.

- Electrical wires are fixed securely?
- Water drain pipes are connected correctly?
- Ground wires are connected securely?
- Supply voltage conforms to relevant electric codes?
- The control panel works well?
- All noises are normal?
- The water tank has been connected with dedicated pressure relief valve (TP valve) and check valve?
- Materials for hot/cold water pipes conform to requirements of use of hot/cold water?
- After the water system is completed, the water tank is filled with water? Is there water drained out of the water outlet of the hot water pipeline?
- After the water pipe of the water system is filled, check the whole water pipeline. There is no leakage?
- After the water system is filled with water, is there water flowing out after pressure is relieved via the automatic safe pressure relief valve?
- After the water system is filled with water and after leakage check, all outdoor water pipelines are applied with heat insulation treatment?
- The drain valve, drain pipe and pressure relief valve drain pipe of the water tank have been connected to the sewage system and the drainage can be carried out well?

Operation and functions

Display



Functions & Protections

A. Electrical leakage protection

The control system of this machine features an electricity leakage protection function.

B. 3-minutes protection

When starting the machine after electricity input, the system will start after approximately 3 minutes, which is considered to be normal.

When restarting the machine immediately after shutdown, the system goes into the protection mode and starts after approximately 3 minutes, which is considered to be normal.

C. Automatic defrosting function

The defrosting mode is automatically activated if the outdoor temperature is too low and after the compressor already runs continuously for a certain period.

D. Overload protection











The working load of the compressor will be heavy if temperature is high in summer. In order to meet hot water requirements of users and to lengthen service life of the compressor, this product automatically adjusts the fan speed to ensure reliable operation of the compressor.

E. Anti-freezing function









The heat pump starts heating to avoid freezing of the water tank if the temperature in the water tank is too low.

F. The default temperature setting is 55°C.

Description of the pictograms

Symbol	Description
	Power ON/OFF switch
	Working mode selection
	Confirm button
	Timer adjust
	Boost mode. Heat pump and auxiliary power are activated at the same time.
	<p><u>Auto mode</u></p> <ul style="list-style-type: none"> - Optimised management of the heat pump and the electrics for guaranteed comfort ; - Prior using heat pump; - If compressor works more than the default 8 hours , start the auxiliary power ; - The compressor maximum continuous working time () can be adjust in the installer settings.
	<p><u>ECO (off-peak) mode</u></p> <ul style="list-style-type: none"> - In this mode ,priority using heat pump; - In two ways using heat pump,should set in the installer settings; <ol style="list-style-type: none"> 1- timer refer to LP parameter; 2-switch signals by power companies.
	<p><u>Electric heating mode</u></p> <ul style="list-style-type: none"> - In this mode, the electric heating function is turned on, and the electric heating function remains effective. - This function ensures hot water supply when the heat pump is not working properly;
	<p><u>Holiday mode</u></p> <ul style="list-style-type: none"> - According to the vacation dates in advance to prepare hot water; - For example, you leave home for vacation on January 1st and return home on January 5th. The date shall be set as (5-1) =4 days, and corresponding temperature shall also be set. The heat pump will start heating on 00:00 o'clock of January 4th automatically.







Description of the pictograms













Symbol	Description
	Boost mode. Heat pump and Auxiliary electrical heater are activated at the same time(only in AUTO mode).
	Heat pump working icon.
	Auxiliary electrical heater working icon.
	When the PV function is turned on, the setting temperature will be automatically adjusted to 65°C,when the PV effective signal is received, the heat pump and electric heating will be turned on at the same time.
	When receiving the SG signal, the setting temperature will be automatically adjusted to 65°C, and the heat pump will be heated according to the logic of setting the temperature to 65°C.
	Time of peak/off-peak hours. In Time of peak/off-peak hours mode, the symbol corresponding to the mode is displayed. When receiving the signal, "HC" lights up.
	<u>Anti-legionella</u> - Anti-legionella function will be activated every 7 days to heat the tank to 65°C automatically .
	Hot water volume display.

Note: Under certain conditions, ECO mode may result in shortages of hot water (mainly due to air temperatures outside the operating range).

Operating functions

Installer settings

- To open the installer settings, press  switch off the system, then press  and  at the same time for 10 seconds.
- When menu is open, press  or  to change the value of the settings.
- Press  to confirm the settings.
- Press  to close the menu.

Parameters	Description	Factory setting	Adjustment range
 	<u>Off-peak signal type</u> When you use off-peak time clock control, first determine the type of signals, Only allow professional installers to operate. - NO corresponds to Normally Open Signal. - NC corresponds to Normally Close Signal.	NO	NO, NC
  	<u>Off-peak logic type</u> - In two ways using heat pump, should set in the installer settings -01 manually set off-peak time; -02 switch signals by power companies. -03 PV signal. -04 SG signal.	01	01, 02 03, 04
 	<u>Avoid Legionella</u> - This parameter is used to activate the legionella protection mode. - Once every 7 days, all domestic hot water is heated to 65°C.	ON	ON, OF
 	<u>Compressor maximum continuous working time</u> - If the maximum continuous working time of the compressor more than Set Time, start auxiliary power.	15h	5-15h
 	<u>Set the day of the week</u> - Set the day of the week, d1 to d7 for Monday to Sunday, and remember the day of the week.	/	d1-d7
 	<u>Auxiliary Heating in off-peak time</u> - ON corresponds to turned on auxiliary Heating. - OF corresponds to turned off auxiliary Heating.	ON	ON, OF

Checking and maintenance



- Installation and maintenance of the appliance must be done by a qualified professional .
- Before working on the appliance, Shut down the machine and cut off the power supply .
- Do not touch with wet hands.
- Maintenance operations are important to guarantee optimum performance and extend the life of the equipment.

Checking of the Safety valve

- Operate the safety valve at least once **every six months** to check if it is running correctly. Otherwise check for blocking and replace the safety valve if necessary.

Checking of the hydraulic circuit

- Check the watertightness of the water connections.

Cleaning of the fan

- Check the cleanliness of the fan one time per year.

Checking of the evaporator



- Because the evaporator fins is very sharp. Risk of injury on your finger.
- Do not damage the fins. Avoid affecting the performance.

- Clean the evaporator at regular intervals using a soft-haired brush.
- If they are bent. Carefully realign the evaporator using a suitable comb.

Checking of the condensates discharge pipe

- Check the pipe cleanliness .
- An obstruction by dust may cause poor condensates flow or even a risk accumulation of water in the heat pump plastic base.

Checking of the Magnesium rod

- The magnesium anode should be replaced in time, avoid tank corrosion.
- Checking magnesium anode once every 2 years .In poor water areas need to shorten the time.

Drain the water tank to empty

- Cut off power supply and shut down water inlet valve, then drain the water tank to empty via the sewage outlet. Please stay away from the sewage outlet if there is hot water inside the water tank to avoid injury.

Faults and protection

Fault type	Action	Digital indication	Release
Compressor protection	Operating temperature protection	F2	After fault is solved, switch on power supply for release
	Air exhaust temperature protection	F3	
	Evaporation high temperature protection	F5	
Compressor over-current protection	Over-current protection	F6	
Electricity leakage alarming	The system will automatically cut off power supply if any line fault occurs	E1	After fault is solved, switch on power supply for release
Over temperature alarming	The actual water temperature $\geq 85^{\circ}\text{C}$	E2	
Fault of the inner temperature sensor	If short circuit or circuit break occurs to the sensor	E3	
Fault of the ambient temperature sensor	If short circuit or circuit break occurs to the sensor	E4	
Fault of the evaporation temperature sensor	If short circuit or circuit break occurs to the sensor	E5	
Fault of the air exhaust temperature sensor	If short circuit or circuit break occurs to the sensor	E6	
Fault of the air intake temperature sensor	If short circuit or circuit break occurs to the sensor	ED	
Communication fault	Communication of main control panel and display panel is abnormal	E7	
Pressure switch protection	Action of the pressure switch at the exhaust outlet	E8	
Ambient temperature protection	Ambient or outdoor temperature $< -7^{\circ}\text{C}$ or $> 45^{\circ}\text{C}$	E9	
Fault of the Off-peak power switching signal	If not received the Off-peak signal when selecting switch signals by power companies	EF	
Fault of the fan	Fan blade is stuck or fan and control panel communication failure	L7	



The  symbol on the product or on its packaging indicates that this product is not to be treated as regular household waste. Instead, it must be taken to a recycling collection point for electrical and electronic equipment. By properly disposing of this product, you are contributing to the preservation of the environment and the wellbeing of your fellow citizens. Improper disposal is hazardous to health and environment. You can obtain further information on how to recycle this product from your municipality, your waste management service or the shop where you purchased it.

Product Fiche

Model		HP150M5
Power supply	Ph/V/Hz	AC220-240V, 50Hz
The water heating energy efficiency (η_{wh})	%	123.39
Water heating energy efficiency class	-	Class A+
Annual energy consumption (AEC)	kWh/annum	830
The daily electricity consumption (Q_{elec})	kWh	3.896
The sound power level (indoors)	dB(A)	50
Mixed water at 40 °C	L	195.9
Load profiles of water heaters, Type	-	L
Manufacturer	Qingdao Economic & Technology Development Zone Haier Water-Heater Co.,Ltd.	
Address	Haier Industry Park, Economic & Technology Development Zone, 266101 Qingdao, PEOPLE'S REPUBLIC OF CHINA	
Denomination	Heat pump water heater	
Intended use	Hot water	
Assembly type	single package	
Refrigerant	R134a/460g	

Haier

0040510083
20210218
V*****